

amplicomms

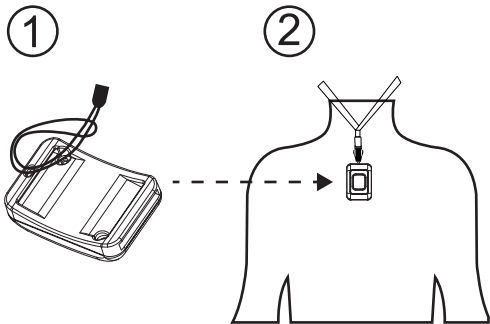

**BigTel 50 Alarm^{Plus}
SOS Button**
www.amplicomms.com

— 1 —

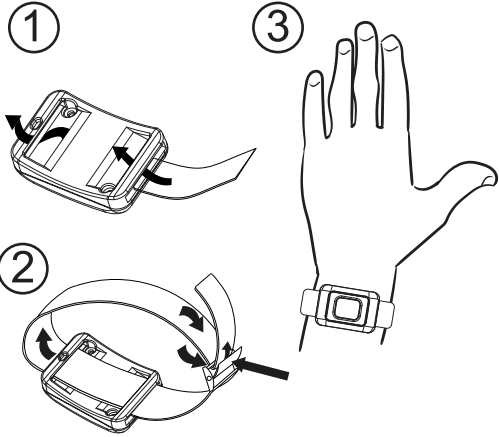

— 2 —

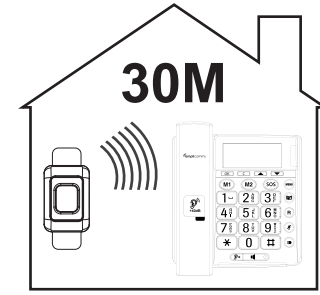
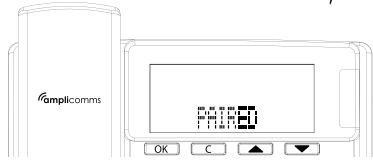
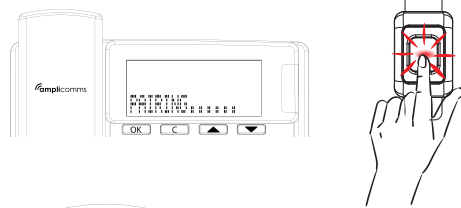
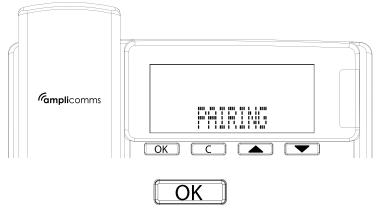
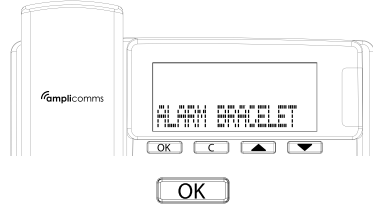
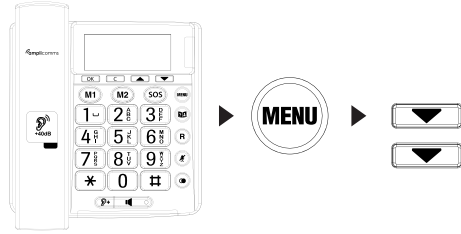

— 3 —

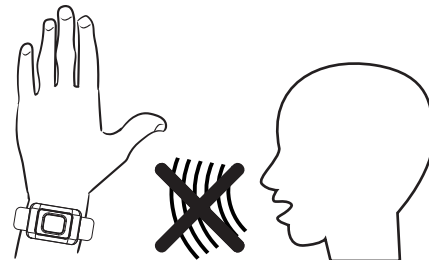
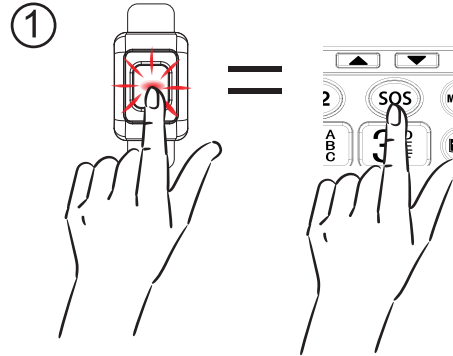

— 4 —

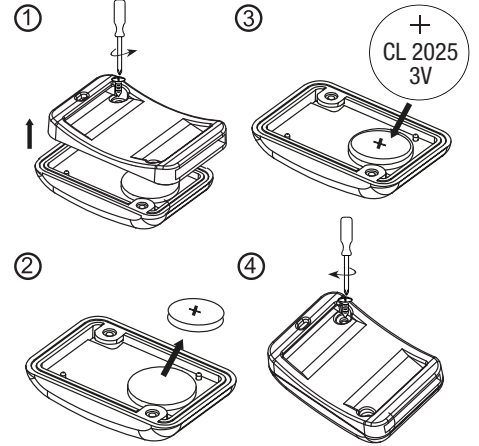
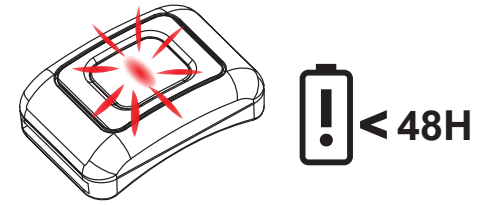

— 5 —

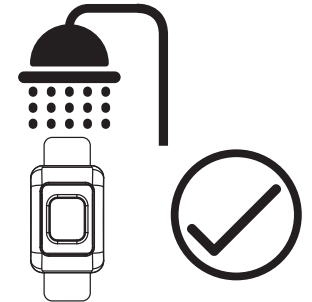

— 6 —



ENGLISH

SAFETY

- The unit is splash water proof, but must never be submerged in water.
- Keep the unit clean and dry to prevent skin irritations.
- Battery replacement may be performed in accordance with the instructions. Only use recommended battery type as stated in this manual. CAUTION – Risk of explosion if battery is replaced by an incorrect type.

ENVIRONMENT

 This symbol means that your inoperative electronic appliance must be collected separately and not mixed with the household waste. The European Union has implemented a specific collection and recycling system for which producers are responsible.

Help us protect the environment in which we live!

DECLARATION OF CONFORMITY

The logo printed on the products indicates the conformity with all essential requirements (RED directive : 2014/53/EU). You can download the Declaration of Conformity from our website - www.amplicomms.com

UK
CA

Hereby, ATLINKS EUROPE declares that the radio equipment is in compliance with Legislation : Radio Equipment Regulations 2017 (SI 2017/1206). The full text of the UKCA declaration of conformity is available at the following internet address:

www.amplicomms.com

- MAX output power (NTP) : 10dBm
- Frequency range : 433.92MHz

FRANCAIS

SÉCURITÉ

- L'appareil est étanche aux éclaboussures mais ne doit jamais être immergé dans l'eau.
- S'assurer que l'appareil demeure propre et sec pour prévenir les irritations de la peau.
- Le remplacement des batteries doit être effectué selon les instructions. Utiliser uniquement le type de batteries indiqué dans ce manuel. ATTENTION - Risque d'explosion si la batterie est remplacée par un type de batterie incorrect.

ENVIRONNEMENT

 Le téléphone que vous avez acheté, ainsi que les piles usagées, ne doivent pas être jetés avec les ordures ménagères. Vous devez les rapporter à votre distributeur, en cas de remplacement, ou les déposer dans un point de collecte prévu à cet effet.

Aidez-nous à protéger l'environnement dans lequel nous vivons!

CONFORMITE



Le logo imprimé sur l'appareil atteste que ce dernier est conforme aux exigences essentielles de la directive RED (2014/53/EU). Vous pouvez consulter cette déclaration de conformité sur notre site Web: www.amplicomms.com

- Puissance d'émission maximale : 10dBm
- Plage de fréquence : 433.92MHz

ESPAÑOL

SEGURIDAD

- La unidad es resistente a salpicaduras, pero nunca se debe sumergir en agua.
- Mantenga la unidad limpia y seca para evitar irritaciones cutáneas.
- La sustitución de las baterías solo se debe realizar de acuerdo con las instrucciones. Utilice únicamente el tipo de batería recomendado en este manual. PRECAUCIÓN: existe riesgo de explosión si cambia las baterías por un modelo incorrecto.

MEDIO AMBIENTE

 Este símbolo indica que el aparato eléctrico fuera de uso se debe desechar de forma independiente y nunca junto a los residuos domésticos. Con este propósito, la Unión Europea ha establecido un sistema de recolección y reciclaje específico en el que la responsabilidad recae sobre los productores. *¡Ayúdenos a conservar el medioambiente en el que vivimos!*

CONFORMIDAD



Este logo indica el cumplimiento con los requisitos esenciales y otras disposiciones de las directivas aplicables. Directiva de equipos de radio (RED): 2014/53/UE. Pueden consultar la declaración de conformidad en nuestra página web - www.amplicomms.com

- Potencia máxima de salida (NTP) : 10dBm
- Rango de frecuencia : 433.92MHz

DEUTSCH

SICHERHEIT

- Das Gerät ist nur spritzwassergeschützt, d. h., es darf nie in Wasser eingetaucht werden.
- Halten Sie das Gerät sauber und trocken, um Hautirritationen zu vermeiden.
- Der Austausch der Batterien darf nur gemäß der Anleitung durchgeführt werden. Nur empfohlene Batterietypen verwenden, so wie in diesem Handbuch angegeben. ACHTUNG – Wird ein falscher Akkutyp eingelegt, besteht Explosionsgefahr.

UMGEBUNG

 Dieses Symbol zeigt an, dass Ihr außer Betrieb befindliches Gerät getrennt eingesammelt und entsorgt werden muss. Die Europäische Union hat ein spezielles Sammel- und Recyclingsystem eingeführt, für das die Hersteller zuständig sind.

Helfen Sie uns, die Umwelt, in der wir leben, zu s chützen!

KONFORMITÄT



Die gedruckte Kennzeichnung auf dem Produkt besagt, dass das Produkt alle Anforderungen und gültigen Richtlinien für diese Produkt erfüllt (Richtlinie 2014/53/EU). Die Konformitätserklärung können Sie auf unserer Webseite : www.amplicomms.com herunterladen.

- Maximale Ausgangsleistung (Netzwerkendstelle) : 10dBm
- Frequenzbereich : 433.92MHz

PORTUGUÊS

EGURANÇA

- A unidade é à impermeável, mas nunca deve ser mergulhada em água.
- Mantenha a unidade limpa e seca para evitar irritações na pele.
- A troca da pilha deve ser feita de acordo com as instruções. Utilize apenas o tipo de pilha recomendado neste manual. ATENÇÃO - risco de explosão se a pilha for trocada por um tipo incorreto.

AMBIENTE

 Este símbolo significa que o seu aparelho electrónico inoperativo deve ser recolhido separadamente e não misturado com o lixo doméstico. A União Europeia implementou um sistema de recolha e reciclagem específico pelo qual os produtores são responsáveis. *Ajude-nos a proteger o ambiente onde vive!*

CONFORMIDADE



Este logotipo mostra que os produtos se encontram em conformidade com os requisitos essenciais e outras disposições aplicáveis da (Diretiva de Equipamento de Rádio: 2014/53/UE). Podem consultar a declaração na nossa página web - www.amplicomms.com

- Potência de Saida Máxima (NTP) : 10dBm
- Gama de Frequência : 433.92MHz

ITALIANO

SICUREZZA

- L'unità è resistente agli schizzi, ma non deve essere in alcun caso immersa in acqua.
- Conservare l'unità pulita e asciutta per evitare irritazioni cutanee.
- La sostituzione delle batterie deve essere effettuata in conformità alle istruzioni. Usare unicamente il tipo di batteria indicato nel presente manuale. ATTENZIONE: l'uso di un tipo di batteria non corretto comporta un rischio di esplosione.

AMBIENTE

 Questo simbolo sta a indicare che un apparecchio elettronico non più pervativo deve essere smaltito separatamente e non mescolato ai rifiuti domestici. L'Unione Europea ha messo in opera un sistemaspecifico di raccolta e riciclaggio, di cui sono responsabili i produttori. *Aiutateci a proteggere l'ambiente in cui viviamo!*

CONFORMITA



Il logo riportato sui prodotti indica la conformità a tutte le norme essenziali e a tutte le direttive applicabili (Direttiva RED: 2014/53/UE). Il testo completo della dichiarazione di conformità UE è disponibile al seguente indirizzo Internet : www.amplicomms.com

- Massima Potenza in uscita (NTP) : 10dBm
- Range di Frequenza : 433.92MHz

DUTCH

VEILIGHEID

- De eenheid is spatwaterdicht, maar mag nooit in water worden ondergedompeld.
- Houd de eenheid schoon en droog om huidirritatie te voorkomen.
- De batterijen mogen uitsluitend in overeenstemming met de instructies worden vervangen. Gebruik uitsluitend het aanbevolen type batterijen dat in deze handleiding wordt vermeld. VOORZICHTIG – Er is ontploffingsgevaar als de batterij wordt vervangen door een verkeerd type.

MILIEU

 Dit symbool betekent dat uw niet meer werkende elektronische toestel afzonderlijk moet worden ingezameld en niet met het huisvuil mag worden vermengd. De Europese Unie heeft een specifiek inzamel- en recyclingsstelsel ingevoerd waarvoor de fabrikanten verantwoordelijk zijn. *Help ons het milieu waarin we leven te beschermen!*

CONFORMITEIT



Het op de producten afgedrukte logo geeft de conformiteit aan met alle essentiële eisen en alle toepasselijke richtlijnen (Radioapparatuur Richtlijn: 2014/53/UE). U kunt de conformiteitsverklaring downloaden vanaf onze website - www.amplicomms.com

- Maximale uitgangsvermogen (NTP) : 10dBm
- Frequentiebereik : 433.92MHz

DANSK

SIKKERHED

- Enheden er stænkvandstæt, men må aldrig nedsænkes i vand.
- Hold enheden ren og tør for at undgå hudirritationer.
- Udskiftning af batteriet kan foretages i overensstemmelse med vejledningen. Brug kun den anbefalede batteritype som angivet i denne vejledning. FORSIGTIG - Eksplosionsfare, hvis batteriet udskiftes med en forkert type.

MILJØINFORMATION

 Dette symbol betyder, at brugte elektroniske apparater, skal bortskaffes separat. De må ikke bortskaffes med husholdningsaffald. EU har implementeret et særligt system til indsamling og genbrug, som producenterne er ansvarlige for. *Hjælp os med at beskytte vores miljø!*



OVERENSSTEMMELSESERKLÆRING

Denne enhed opfylder alle kravene i (RED-direktiverne : 2014/53/EU). Dette bekræftes af CE-symbolet på enheden. EU-overensstemmelseserklæringens fulde tekst kan findes på følgende internetadresse: www.amplicomms.com

- Maksimal udgangseffekt (NTP) : 10dBm
- Frekvensområde : 433.92MHz

SVENSKA

SÄKERHET

- Enheten är stånkskyddad, men får aldrig nedsänkas i vatten.
- Håll enheten ren och torr för att förhindra hudirritation.
- Batteriet kan bytas ut i enlighet med instruktionerna. Använd endast den rekommenderade batteritypen som anges i den här handboken. FÖRSIKTIGHET - Explosionsrisk om batteriet byts ut mot en felaktig typ.

MILJÖ

 Denna symbol innebär att din trasiga elektroniska apparat måste, kasseras separat och inte blandat med övrigt avfall. Den Europeiska Unionen har implementerat ett specifikt insamlings- och återvinningssystem där producenten är ansvariga. *Hjälp oss att skydda den miljö vi lever i!*

CONFORMITEIT



Den logo som är tryckt på produkterna meddelar efterföljande av alla nödvändiga krav (RED-direktivet: 2014/53/UE). Du kan ladda ner deklarationen om regel efterlevnad från vår hemsida : www.amplicomms.com

- Maksimal udgangseffekt (NTP) : 10dBm
- Frekvensområde : 433.92MHz

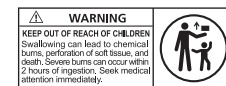

ATLINKS

ATLINKS Europe
28 Boulevard Belle Rive
92500 RUEIL-MALMAISON, France
RCS Nanterre 508 823 747

ATLINKS UK Ltd

3rd Floor, Waverley House
7-12 Noel Street, London, W1F 8GQ. UK

© ATLINKS 2022 - Reproduction prohibited.
www.amplicomms.com

The Manufacturer reserves the right to modify the specifications of its products to make technical improvements or comply with new regulations.

Amplicomms is a trademark of Swissvoice International SA.

Amplicomms BT50 Alarm Bracelet
AW No.: 10002664 Rev.0
Printed in China